

(19) World Intellectual Property Organization
International Bureau



(43) International Publication Date
28 June 2001 (28.06.2001)

PCT

(10) International Publication Number
WO 01/46457 A2

- (51) International Patent Classification⁷: C12Q 1/00, 1/32
- (72) Inventors: WILSEY, Christopher, D.; 516 Oak Drive, Carmel, IN 46032 (US). BURKE, David, W.; 1931 Madison Court, Carmel, IN 46032 (US).
- (21) International Application Number: PCT/US00/33986
- (74) Agent: WOODBURN, Jill, L.; The Law Office of Jill L. Woodburn, L.L.C., 6633 Old Stonehouse Drive, Newburgh, IN 47630 (US).
- (22) International Filing Date:
14 December 2000 (14.12.2000)
- (25) Filing Language: English
- (81) Designated States (*national*): AE, AG, AL, AM, AT, AU, AZ, BA, BB, BG, BR, BY, BZ, CA, CH, CN, CR, CU, CZ, DE, DK, DM, DZ, EE, ES, FI, GB, GD, GE, GH, GM, HR, HU, ID, IL, IN, IS, JP, KE, KG, KP, KR, KZ, LC, LK, LR, LS, LT, LU, LV, MA, MD, MG, MK, MN, MW, MX, MZ, NO, NZ, PL, PT, RO, RU, SD, SE, SG, SI, SK, SL, TJ, TM, TR, TT, TZ, UA, UG, UZ, VN, YU, ZA, ZW.
- (26) Publication Language: English
- (30) Priority Data:
09/469,899 22 December 1999 (22.12.1999) US
- (71) Applicant: ROCHE DIAGNOSTICS CORPORATION [US/US]; 9115 Hague Road, P.O. Box 50457, Indianapolis, IN 46250-0457 (US).
- (84) Designated States (*regional*): ARIPO patent (GH, GM, KE, LS, MW, MZ, SD, SL, SZ, TZ, UG, ZW), Eurasian patent (AM, AZ, BY, KG, KZ, MD, RU, TJ, TM), European

[Continued on next page]

(54) Title: AMPEROMETRIC BIOSENSOR TEST STRIP

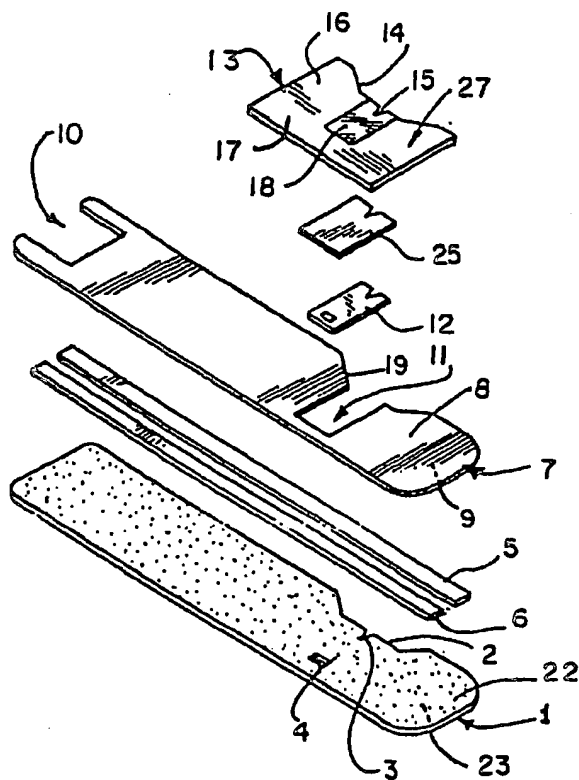

(57) Abstract: A reagent and method for determining the levels of 3-hydroxybutyric acid in a sample are provided. The reagent comprises a ferricyanide salt, a catalytic amount of a first enzyme operative to catalyze the oxidation of 3-hydroxybutyric acid in the sample, a cofactor corresponding to said first enzyme, and a catalytic amount of a second enzyme operative to catalyze the oxidization of the cofactor and the reduction of the ferricyanide. The reagent is incorporated into a test strip that generates an electrical output signal indicative of the level of 3-hydroxybutyric acid when the reagent is contacted with a sample.



WO 01/46457 A2

FIRST AVAILABLE COPY

AMPEROMETRIC BIOSENSOR TEST STRIP

Field of the Invention

This invention relates to the determination of the concentration of analytes in fluids and
5 more specifically to an amperometric biosensor for use in such determination. Most particularly,
this invention relates to an amperometric biosensor used in the determination of 3-
hydroxybutyric acid levels in fluids.

Background and Summary of the Invention

10 3-hydroxybutyric acid (hereinafter "3-HBA") is produced by incomplete fatty acid
metabolism in the liver under conditions involving the impaired utilization or inadequate supply
of carbohydrates. Whenever increased amounts of fats are metabolized, such as when the
carbohydrate intake is restricted, the concentration of ketone bodies such as 3-HBA, acetone, and
acetoacetic acid can increase. If ketone bodies are present in the blood in an excessive amount,
15 the condition is termed ketosis.

Diabetes mellitus is a disorder associated with ketosis. Diabetes mellitus is a disorder of
glucose metabolism. In insulin-deficient diabetes, glucose metabolism is sufficiently impaired
such that fatty acids are utilized to meet the energy requirements of the body. If excessive
amounts of fatty acids are metabolized, ketone bodies accumulate in the blood, i.e., ketosis, and
20 are excreted in urine, i.e. ketonuria. In addition, ketone bodies are excreted from the body in
combination with normal basic ions, thereby reducing the carbon dioxide combining power of
the body and causing systemic acidosis, i.e. increased acidity of the blood. The term
ketoacidosis designates the combined ketosis and acidosis conditions associated with diabetes.
At elevated levels, 3-HBA is diagnostic of ketoacidosis.

25 Detecting ketoacidosis in a patient with diabetes mellitus is beneficial in that it often
indicates the necessity of a change in insulin dosage or other management procedures. One
approach to determine the presence or concentration of ketone bodies in a sample has been to
subject the sample to a colorimetric assay. For example, it is well known to determine the
presence or concentration of ketone bodies by contacting a liquid sample with an indicator
30 reagent composition that undergoes a color transition upon contact with the sample. See for
example, U.S. Patent Nos. 4,803,158; 5,326,697; 5,510,245; and 5,190,863.

Amperometric assays for ketone bodies have also been used. See for example,
PCT/US98/21815, filed Oct. 16, 1998, and Batchelor, et al., *Amperometric Assay for the Ketone
Body Hydroxybutyrate*, *Analytic Chimica Acta*. 289-294 (1989). These assays utilize enzymes
35 to catalyze the oxidation of 3-HBA, the oxidizable form of a cofactor, and an oxidant such as, for
example, a quinone.

Brief Description of the Drawings

FIG. 1 is an exploded perspective view of a test strip showing the strip including a first insulating substrate, electrically conductive tracks formed to lie on first insulating substrate, a test reagent aligned with the tracks, a second insulating substrate, a hydrophilic coating, and a roof;

FIG. 2 is perspective view of the test strip of FIG. 1;

FIG. 3 is a cross-sectional view taken along lines 28-28 of Fig. 2 showing the relative positioning of the electrodes, reagent, and hydrophilic film between the first and second insulating substrates;

FIG. 4 is a cross-sectional view taken along lines 29-29 of Fig. 2 showing the roof, the hydrophilic film, the edges of the second opening of the second substrate, and the first insulating substrate cooperating to define a test chamber and the reagent positioned in the test chamber; and

FIG. 5 is a graph showing calibration curves for different lots of test strips.

Detailed Description of the Invention

The field of electrochemistry is based on the phenomenon that many metals, metal ions, and conjugated molecules easily accept and/or release electrons. Compounds have a standard potential, which is the energy level at which the compound is equally likely to release or accept electrons. Whether a compound is oxidized or reduced is dependent upon whether the potential applied to that compound is greater or less than its standard potential. The present invention relies upon an electrochemical technique known as amperometry, which involves applying a potential and collecting the moving electrons as current.

It has been discovered that hexacyanoferrate (III) salts may be used as mediators and incorporated into an amperometric biosensor test strip that generates an electrical output signal indicative of the level of 3-HBA in a sample. The use of hexacyanoferrate (III) salts as mediators in a test strip for 3-HBA is advantageous, because the corresponding test strip is compatible with existing amperometric glucose meters, allowing testing of ketones and glucose in one meter. The term mediator as used in the specification and claims comprises oxidants that are capable of undergoing an electrochemical, reversible, oxidation-reduction reaction. The oxidized form of the mediator must be capable of receiving at least one electron from a reaction involving an enzyme, analyte (or cofactor produced from analyte reaction) and the oxidized form of the mediator.

These mediators can be used in the manufacture an amperometric biosensor test strip for an analyte such as 3-HBA, which generates an electrical output indicative of the level of 3-HBA in the applied sample. The test strip is formed to receive biological samples such as whole blood, serum, plasma, and the like. The test strip includes a reagent that comprises a mediator, a

Crismore et al., the disclosure of which is incorporated herein by reference. It is appreciated, however, that the test strip may be similar to the biosensors disclosed in U.S. Patent Nos. 5,288,636 to Pollmann et al. and 5,762,770 to Pritchard et al., as well as any number of commercially available architectural environments for glucose measuring sensors without
5 exceeding the scope of the present disclosure.

Referring specifically to Figs. 1-2, the biosensor test strip of the present invention includes a first insulating substrate 1, a second insulating substrate 7, electrically conductive tracks 5, 6 situated between substrates 1, 7, a testing reagent 12, a generally hydrophilic film 25 in general alignment with testing reagent 12, and a roof 13 positioned over film 25. Reagent 12,
10 as will be discussed hereafter, comprises the reagent composition of the present invention. In addition, test strip is produced from rolls of material. Thus, the selection of materials for the construction of the test strip necessitates the use of materials that are sufficiently flexible for roll processing, but which are still rigid enough to give a useful stiffness to the finished test strip.

First substrate 1 includes a first surface 22 that supports conductive tracks 5, 6 and an
15 opposite second surface 23. See Fig. 1. First substrate 22 further includes an indentation 2, a notch 3, and a vent hole 4 extending between first and second surfaces 22, 23. Substrate 1 may be constructed from a wide variety of insulating materials. Non-limiting examples of insulating materials that provide desirable electrical and structural properties include vinyl polymers, polyimides, polyesters, and styrenics. The first insulating substrate 1 is 7 mil thick MELINEX®
20 329 plastic, a polyester available from DuPont (3411 Silverside Road, PO Box 15391, Wilmington, Delaware 19850).

As shown in Fig. 1, electrically conductive tracks 5 and 6 are laid down onto first surface 22 of first insulating substrate 1. Track 5 may be a working electrode and track 6 may be a counter electrode. Tracks 5, 6 are constructed from electrically-conductive materials.
25 Specifically, track may be constructed of palladium, platinum, gold, carbon, and titanium. Track 6 may be constructed of palladium, platinum, gold, silver, silver containing alloys, nickel-chrome alloys, carbon, titanium, and copper.

Electrically conductive tracks 5 and 6 are deposited on an insulative backing, such as polyimide or polyester, to reduce the possibility of tearing the electrode material during handling
30 and manufacturing of the test strip. An example of such conductive tracks is a palladium coating with a surface resistance of less than 5 ohms per square on the polyimide UPLEX from UBE INDUSTRIES, LTD., Japan, which is available pre-coated with gold, palladium or platinum from TECHNI-MET of Connecticut, USA.

Electrically conductive tracks 5 and 6 represent the electrodes of the biosensor test strip.
35 These electrodes must be sufficiently separated so that the electrochemical events at one

an indentation 14 and a notch 15 formed in window 18 that are shaped and positioned in general alignment with indentation 2 and notch 3 of first substrate 1. Notches 2, 15 can be defined as a generally triangular cutout from the affected edges with a length of about 0.6 to 1.3 mm and an angle at the opposite vertex of about 70-110 degrees. It is appreciated that the dimensions and configuration of notch may vary in accordance with this disclosure.

Roof 13 may be constructed of a plastic material, such as a transparent or translucent polyester foil that has a thickness of about 2 mil (0.05 mm) to 6 mil (0.15 mm) thickness. Roof 13 is constructed of MELINEX[®] 351 (polyester, containing titanium dioxide to provide opacity) which has been coated with a pressure sensitive adhesive. A non-limiting example of a suitable adhesive is 3 M 9458 acrylic, available from 3M, Identification and Converter Systems Division, St. Paul, MN, US.

Additionally, roof 13 is either intrinsically hydrophilic or has been modified such that roof 13 possesses a hydrophilic surface, which is oriented toward second substrate 7. Surface 17 is modified by hydrophilic film 25, which is positioned onto the adhesive of surface 17. Hydrophilic film 25 is made hydrophilic, for example, by coating film with a detergent containing coating or a photo-crosslinked matrix of hydrophilic polymer. The film may also be modified through plasma treatment or plasma induced, covalent, modification of the surface with sulfonyl- or nitrous- groups. Hydrophilic film 25 is coated with a mixture of VITEL (The Goodyear Tire & Rubber Co., Akron, OH, US) and RHODAPEX[®] (Rhodia, Cranbury, NJ, US) surfactant at an approximate thickness of about 4 mil (0.1 mm).

The capillary test chamber is defined by second surface 17 of roof 13 having hydrophilic film 25 coupled thereto, the edges of second opening 11 of second substrate 7, and first surface 22 of substrate 1. The test chamber is positioned to expose a portion of tracks 5, 6 for application of reagent 12 to those exposed surfaces of tracks 5, 6. The length and width of this capillary test chamber are defined by the length and width of opening 11 and the height of the test chamber is defined by the thickness of second substrate 7. The test chamber is formed as a rectangle of about 3.2mm on one side and about 6.7mm on the other side. The degree to which tracks 5, 6 are exposed determines the surface area for each electrode. The working and counter electrodes 5, 6 each have substantially equivalent surface areas of about 5mm². It is appreciated, however, that the degree of exposure of tracks 5, 6 may vary, as long as second opening 11 exposes at least about 10% of the width of each track 5, 6.

Reagent 12 for 3-HBA is positioned in the test chamber such that it covers working electrode 5. Reagent 12 is placed as a film of generally uniform thickness over the entire floor surface of the test chamber. Reagent 12 will then present a hydrophilic surface to the interior of the test chamber. Reagent 12 is formed to include a vent in general alignment with venting hole

The 3-HBA test reagent of the present invention further includes enzymes that are of sufficient type and in sufficient amount to catalyze the reaction involving enzyme, analyte, and oxidized form of the mediator. One enzyme suitable for use in the reagent is operative to catalyze the oxidation of 3-HBA in the sample and a second enzyme is operative to catalyze the electrochemical oxidation of a reduced form of the cofactor. The first enzyme is a dehydrogenase and a second enzyme is diaphorase. More particularly, the first enzyme is 3-hydroxybutyrate dehydrogenase that is commercially available from Toyobo Co., Ltd. Biochemical Operations Department, Osaka, Japan and Roche Diagnostics Corporation, Roche Molecular Biochemicals, Indianapolis, IN, US. The diaphorase is commercially available from Roche Diagnostics Corporation, Roche Molecular Biochemicals, Indianapolis, IN, US.

For the test strip as designed for the analysis of 3-HBA, between about 0.20 and 20 million units of 3-hydroxybutyrate dehydrogenase and between about 0.1 and 10 million units of diaphorase per liter of reagent are included where the reaction is allowed to proceed for about 15 seconds at a minimum before the application of electrical potential. More preferably, the reaction is allowed to proceed for about 50 seconds at a minimum before the application of electrical potential. It is appreciated, however, that the amount of enzymes included in the reagent may vary depending upon the desired stability, the geometry of the electrodes, and the physical properties of the reagent film without exceeding the scope of the present disclosure.

Additionally, the test reagent comprises a cofactor that cooperates with the enzymes and the mediator. Non-limiting examples of suitable cofactors include NAD^+ , NADP^+ , NADH_2 , NADPH_2 , and phenazine methosulfate. Preferably, the cofactor is NAD^+ . NAD^+ is commercially available from Roche Diagnostics Corporation, Roche Molecular Biochemicals, Indianapolis, IN, US. The reagent for analyzing 3-HBA includes about 21.1 μM to 43 μM NAD^+ , based on 663.44 g/mol, to measure the 3-HBA level in a sample of human whole blood from about 3.5 to 7 microliters (μL) in volume. It is appreciated that greater than 7 μL of sample may be deposited onto test strip, but that the concentration of NAD^+ in the dissolved reagent is dependent only upon the amount of sample that enters the test chamber. It is also appreciated, however, that the concentration of NAD^+ will vary with the volume of human whole blood that enters the test chamber.

To improve the solubilization of the mediator, various "filler" substances can be included in the reagent. A filler is defined here as an insoluble particulate of microscopic size that is evenly dispersed through the reagent matrix during the compounding of reagent. The preferred filler is a metal oxide that does not accept or donate electrons at the applied potential or relative to the potential of the mediator or mediators. Reagent 12 includes a filler such as titanium dioxide present in an amount from about 0.2 to 2.0% (wet mass: wet mass) and is preferably about 0.22% (wet mass: wet mass).

level. The concentration of buffer generally used is between about 50 and 200mM in the reagent. The preferred concentration is about 53.6mM.

The reagent may also contain substances that stabilize the various components. Acceptable stabilizers for the enzymes in combination with a cofactor in the reagent of the present invention are flavin mononucleotide, adenosine diphosphate, magnesium ions, lactose, 5 trehalose, and raffinose. Reagent 12 includes a stabilizer such as raffinose in a concentration of about 0.5 to 5% (wet mass: wet mass), with about 0.68% (wet mass: wet mass) being preferred.

The dried reagent film thickness will be such that, in combination with the inherent properties of the chemistry, the sensitivity of the system to interference from hematocrit variation 10 is mitigated. The film thickness (as gauged by the ratio of wet reagent dispense volume to the surface area dispensed onto) is such that about 10 μ L of reagent is dispensed into an area of about 22.5 millimeters square. The reagent described below, through the use of the principal polymer, polyethylene oxide, and in combination with the film thickness with result in the test strip possessing a reduced sensitivity to hematocrit variation.

15 When a sample containing the analyte 3-HBA is added to the reagent, the analyte is oxidized and the oxidized form of the cofactor is reduced. This cofactor then interacts with a second enzyme and the oxidized mediator is reduced. The reaction is allowed to reach a point in time at which the utilization of analyte and oxidized mediator has reached a point where additional time is not necessary for the accurate determination of analyte concentration. During 20 this incubation time, it may be necessary to place a small magnitude alternating potential across the electrodes to determine the magnitude of interference due to shifts in impedance. See for example, International Application No. PCT/US98/27203, published on July 1, 1999 as International Publication No. WO 99/32881, the disclosure of which is expressly incorporated herein by reference.

25 The oxidization of the analyte and reduction of the oxidized form of the cofactor are permitted to go to completion. The term completion, as used throughout the specification and claims, is defined as a sufficient reaction involving analyte, cofactor, and enzyme to form one or more reduced reaction products and a sufficient reaction involving the one or more reduced reaction products, enzyme, and mediator to correlate the analyte concentration to diffusion 30 limited current generated by oxidation of the mediator at the surface of the working electrode.

After the reactions are complete, a potential difference is applied between a working and counter electrode to cause diffusion limited electro-oxidation of the reduced form of the mediator at the working electrode surface. A current measuring meter measures the diffusion limited current generated by the oxidation of the reduced form of the mediator at the working electrode 35 surface. The measured current may be accurately correlated to the concentration of 3-HBA in the sample when the following requirements are satisfied:

a speed of no less than 600 rpm for no less than 20 minutes. This sub-build is referred to from this point forward as the "Filler-Suspension".

Step 6: The Filler-Suspension from Step 5 was combined with the Polymer Matrix of Step 4. This combination is preformed by filtering the Filler Suspension through a coarse (200
5 micron) mesh to remove any large, undispersed, particles of titanium dioxide prior to or during the combining step.

Step 7: Next, 13.3g of potassium ferricyanide is added to the reagent from Step 6. The reagent is allowed to mix at no less than 500 rpm for not less than 20 minutes or until ready for final reagent assembly (Step 13). This matrix is referred to from this point forward as the
10 "Reagent Base".

Step 8: A separate solution is prepared by dispersing 200,000 units of β -Hydroxybutyrate dehydrogenase enzyme into 100g of deionized water while stirring at a rate no less than 200 rpm using a stir plate and magnetic stirrer.

Step 9: To the solution from Step 8, 200,000 units of Diaphorase enzyme are added and
15 allowed to mix for 10 minutes. This solution is referred to as the "Enzyme Solution" hereafter. The resulting solution is refrigerated at about 4°C to 10°C until ready to incorporate into the final reagent (Step 13).

Step 10: A separate solution is prepared by dissolving 96mg of Magnesium chloride-hexahydrate into 50g of deionized water.

Step 11: To the solution from Step 10, 200mg of cofactor NAD^+ are dissolved while
20 mixing at 200 rpm for 5 minutes.

Step 12: To the solution from Step 11, 145mg of flavin mononucleotide are dissolved while mixing at 200 rpm for 5 minutes. This is referred to as the "Cofactor Solution" hereafter. The Cofactor Solution is refrigerated at about 4°C to 10°C until ready for final incorporation into
25 the reagent (Step 13).

Step 13: The final reagent was assembled by adding the Enzyme Solution from Step 9 and Cofactor Solution from Step 12 to the Reagent Base from Step 7. The final reagent was stirred at a reduced speed of 400 rpm for no less than 15 minutes.

Step 14: The final reagent is completed with the addition of 0.35 g of Triton X-100 and
30 stirring at 400 rpm for no less than 15 minutes prior to dispense.

A test strip of the present invention is manufactured by the process described in U.S. Patent No. 5,997,817, the disclosure of which is incorporated herein by reference. To the test strip, for 3-HBA determination, 10 μL of reagent made by the above-described protocol was added to the electrode-bearing surface of the test-chamber. The amount of reagent may vary
35 from about 3 to 10 μL , with the preferred dispense of about 10 μL . This amount of reagent will substantially cover the surface areas of the electrodes. The resulting reagent film will contain

TABLE 1

wet mass (g)	%	dry mass (g)	mass/g dry mass (mg)	dry %	dry mass/sensor (mg)	component
95.78						DI water
0.61	0.60	0.61	120.8	12.1	0.06010	PEO 750N
0.19	0.19	0.19	37.6	3.8	0.01872	Natrosol 250K
0.23	0.23	0.23	45.6	4.6	0.02266	Titanium Dioxide
0.58	0.57	0.58	114.9	11.5	0.05715	Di Sodium Pyrophosphate
0.73	0.72	0.73	144.8	14.5	0.07202	Tetra Sodium Pyrophosphate
1.33	1.31	1.33	264.1	26.4	0.03137	Potassium ferricyanide
0.68	0.67	0.68	134.7	13.5	0.06700	Raffinose
0.0200	0.0197	0.0200	4.0	0.4	0.00197	NAD+
0.0145	0.0143	0.0145	2.9	0.3	0.00173	Flavin Mononucleotide
0.0096	0.0095	0.0096	1.9	0.2	0.00095	Magnesium Chloride
0.05	0.05	0.05	909	1.0	0.00493	Triton X-100
0.3	0.92	0.47	92.4	9.2	0.09196	β -Hydroxybutyrate dehydrogenase (given 2U/mg)
0.33	0.33	0.13	26.4	2.6	0.03284	Diaphorase enzyme (B.stearothermicus) (given 32U/mg)
101.50		5.05		1000.0		TOTAL

The discrete test strips are used in conjunction with the following:

1. a power source in electrical connection with the working and counter electrodes and capable of supplying an electrical potential difference between the working and counter electrodes sufficient to cause diffusion limited electro-oxidation of the reduced form of the mediator at the surface of the working electrode; and
2. a meter in electrical connection with the working and counter electrodes and capable of measuring the diffusion limited current produced by oxidation of the reduced form of the mediator with the above-stated electrical potential difference is applied.

been achieved. After about 30 seconds, convection becomes significant thereby interfering with the measurement of a diffusion-limited current.

The current measured during the assay of an analyte from a fluid sample may be correlated to concentration of the analyte in the sample by application of an algorithm by the current
5 measuring meter. The algorithm may be a simple one, as illustrated by the following example:

$$[\text{Analyte}] = Ci^{7.5} + d$$

wherein [Analyte] represents the concentration of the 3-HBA analyte in the sample (see Fig. 5), i
10 is the current (in microamps) measured at 9.0 seconds after application of the potential difference applied between the electrodes, C is the slope of the line: e.g. 0.483 for Trial A, and 0.528 for Trial B, and d is the axis intercept: e.g. -2.82 for Trial A and -1.23 for Trial B. Therefore, the concentrations of 3-HBA for Trials A and B were determined as follows:

15

$$\text{Trial A: [3-HBA]} = \text{Current} \times 0.483 - 2.82$$

$$\text{Trial B: [3-HBA]} = \text{Current} \times 0.528 - 1.23$$

By making measurements with known concentrations of 3-HBA analyte, calibration
20 curves may be constructed, as shown in Fig. 5. This calibration will be stored in the Read Only Memory (ROM) key of the meter and will be applicable to a particular lot of biosensors.

In the method for analysis of 3-HBA from a sample of whole human blood, 5 μ L of whole blood is added to the above-described reagent 12. The reaction is allowed to proceed to a stable point, forming a stable concentration of ferrocyanide. During this time, 57mV amplitude, 2kHz
25 frequency alternating current is applied to determine background impedance. About fifty seconds after addition of the whole blood sample, a direct potential difference of about 300 millivolts is applied between the electrodes, thereby oxidizing ferrocyanide to ferricyanide at the surface of the working electrode. Current measurements are made at 0.5 second intervals from 1 second to 9.0 seconds after the potential difference is applied between the electrodes. These
30 current measurements are correlated to the concentration of 3-HBA in the blood sample.

In this example of measuring 3-HBA from a blood sample, current measurements are made at different times (from 1 second to 7.5 seconds after application of the potential difference), rather than at a single fixed time (as previously described), and the resulting algorithm is represented by the following equation:

35

$$[\text{3-HBA}] = C_1 i_1 + C_2 i_2 + C_3 i_3 + \dots C_n i_n + d$$

The present invention has been illustrated by analytes that are oxidized and mediators that are reduced in the presence of a catalytic amount of enzyme. However, the present invention, reagents and methods may be used to measure the concentration of an analyte in a fluid sample, wherein the analyte is reduced and the reduced form of a mediator is oxidized in the presence of a catalytic amount of an enzyme (e.g., a reductase). After the reaction involving analyte, enzyme, and reduced form of the mediator reaches completion, a potential difference is applied between the electrodes. The amount of reduced form of the mediator at the counter electrode (in this case an anode rather than a cathode) and the applied potential difference must be sufficient to cause diffusion limited electroreduction of the oxidized form of the mediator at the surface of the working electrode (in this case a cathode rather than an anode). The diffusion-limited current generated by reduction of the oxidized form of the mediator at the working electrode surface is correlated to the concentration of analyte in the sample being analyzed.

Although the invention has been described in detail with reference to certain preferred embodiments, it is appreciated that variations and modifications exist within the scope and spirit of the present invention as described and defined in the following claims.

17. The apparatus of claim 1, wherein the reagent further comprises a polymer selected from the group consisting of polyethylene glycol/polyethylene oxide, polyvinyl-alcohol, polyvinyl-pyrrolidone, polystyrene sulfonate, polyvinyl-acetate and microemulsions of vinyl-acetate.
- 5 18. The apparatus of claim 1, wherein the reagent further comprises a surfactant.
19. The apparatus of claim 18, wherein the surfactant is selected from the group consisting of sodium dioctyl sulfosuccinate and branched-nonyl phenoxy poly (ethylene-oxy)ethanol.
20. The apparatus of claim 1, wherein the reagent further comprises an inorganic
10 buffer.
21. The apparatus of claim 20, wherein the buffer is a pyrophosphate salt.
22. The apparatus of claim 1, wherein the reagent further comprises stabilizers selected from the group consisting of flavin mononucleotide, adenosine diphosphate, magnesium ions, lactose, and raffinose.
- 15 23. A method for determining information indicative of the level of 3-hydroxybutyric acid in a sample, the method comprising the steps of:
- reacting the sample with a reagent comprising a ferricyanide salt, a catalytic amount of a first enzyme operative to catalyze the oxidation of 3-hydroxybutyric acid in the sample, a cofactor corresponding to said first enzyme, and a catalytic amount of a second enzyme
20 operative to catalyze the oxidization of the cofactor and the reduction of the ferricyanide,
- generating an electrical output from the reagent indicative of the level of 3-hydroxybutyric acid in the sample,
- measuring the electrical output; and
- determining the level of 3-hydroxybutyric acid in the sample using information
25 comprising the measured electrical output.
24. The method of claim 23, wherein the generating step includes applying an electrical potential to the reagent.
25. The method of claim 24, wherein the electrical potential is applied upon completion of the reaction of the sample and the reagent.
- 30 26. The method of claim 25, wherein the reaction is completed in about 60 seconds.
27. A method for determining information indicative of the level of 3-hydroxybutyric acid in a sample, the method comprising the steps of:
- providing a sensor including a working and counter electrodes and a reagent in communication with the electrodes, the reagent comprising a ferricyanide salt, a catalytic amount
35 of a first enzyme operative to catalyze the oxidation of 3-hydroxybutyric acid in the fluid sample,

FIG. 1

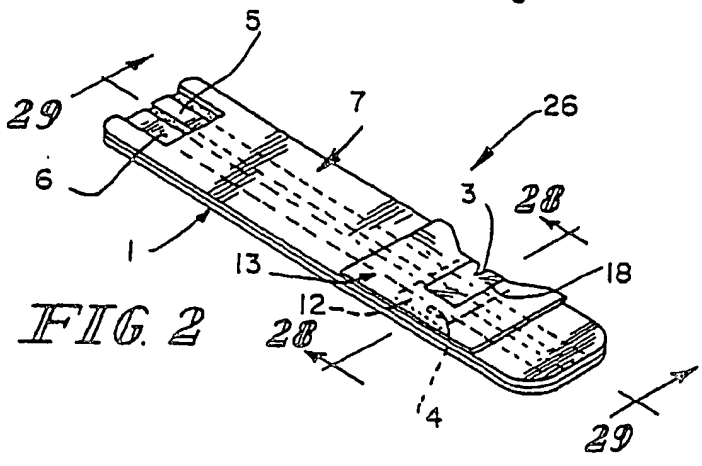
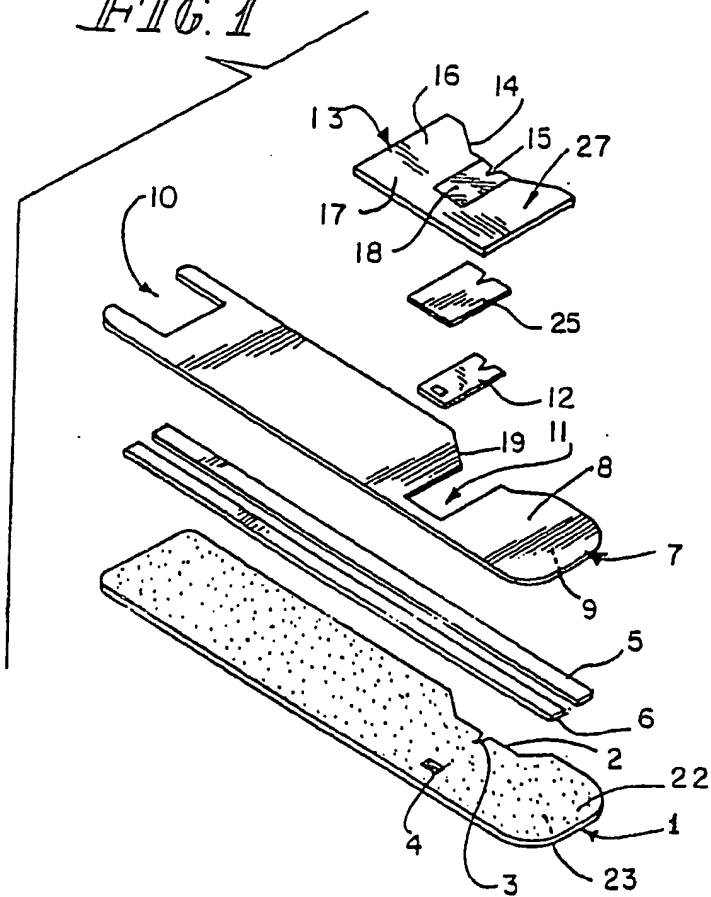
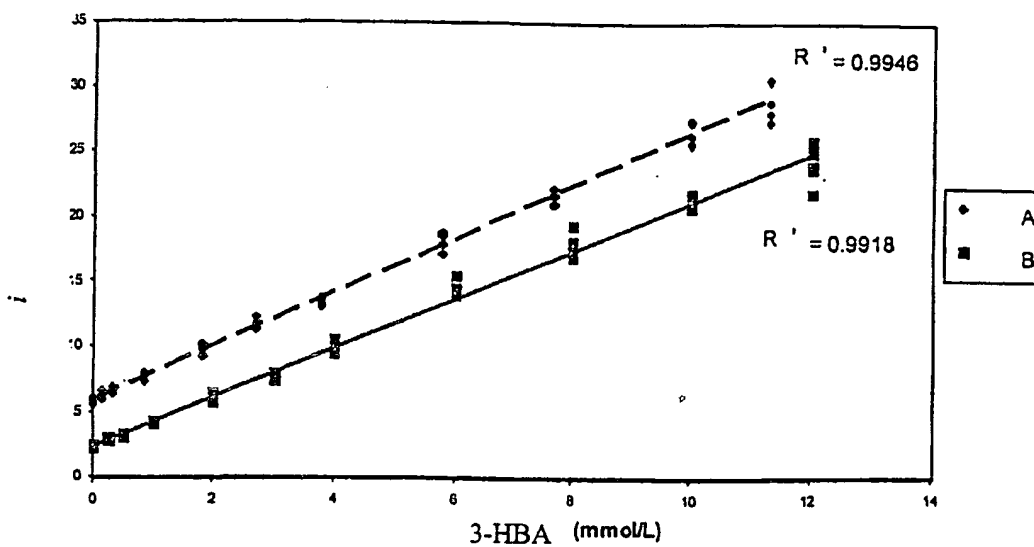

Fig. 5



**This Page is Inserted by IFW Indexing and Scanning
Operations and is not part of the Official Record**

BEST AVAILABLE IMAGES

Defective images within this document are accurate representations of the original documents submitted by the applicant.

Defects in the images include but are not limited to the items checked:

- BLACK BORDERS**
- IMAGE CUT OFF AT TOP, BOTTOM OR SIDES**
- FADED TEXT OR DRAWING**
- BLURRED OR ILLEGIBLE TEXT OR DRAWING**
- SKEWED/SLANTED IMAGES**
- COLOR OR BLACK AND WHITE PHOTOGRAPHS**
- GRAY SCALE DOCUMENTS**
- LINES OR MARKS ON ORIGINAL DOCUMENT**
- REFERENCE(S) OR EXHIBIT(S) SUBMITTED ARE POOR QUALITY**
- OTHER:** _____

IMAGES ARE BEST AVAILABLE COPY.

As rescanning these documents will not correct the image problems checked, please do not report these problems to the IFW Image Problem Mailbox.